

*Soldering residues not permissible (seal)*  
Lötrückstände nicht zulässig (Dichtung)

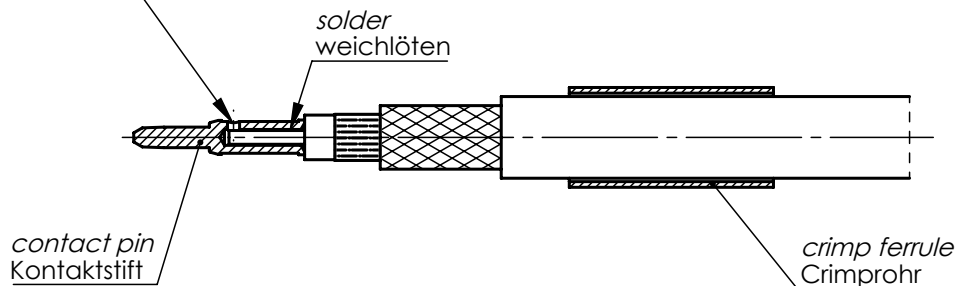

*Insert cable with contact pin slowly over seal into the housing*  
Kabel mit Kontaktstift langsam über Dichtung ins Gehäuse einführen

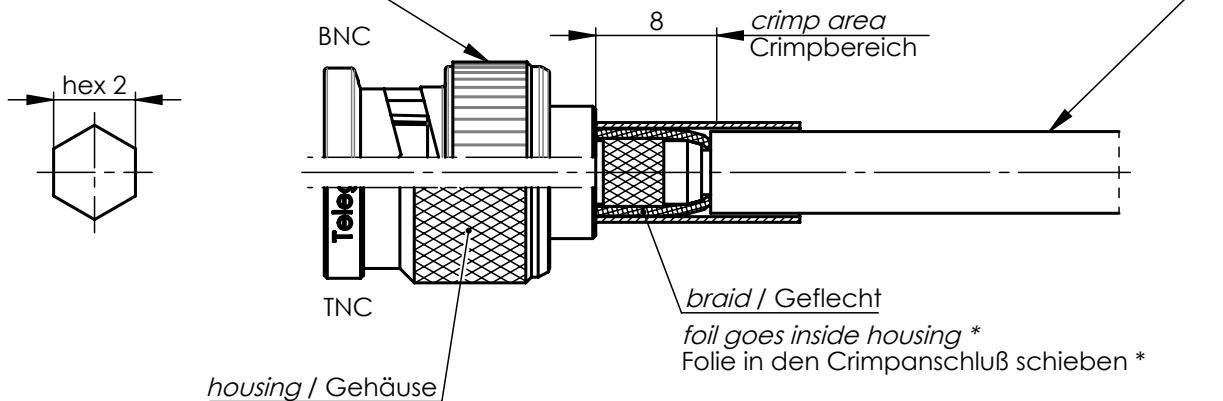

*\* only for cables with foil / \* nur für Kabel mit Folie*

xx	crimp insert Crimpeinsatz	hex 1 x length 6kt 1 x Länge	hex 2 x length 6kt 2 x Länge		
05	N01003A0005		5,41 x 8		

c b a	29413	22.02.2018	JA
	29381	12.02.2018	JA
	28890	11.07.2017	MA
Änd./ rev. Index	Änderungs-Nr. / revision code	Datum/ date	Name/ name

	Datum/ date	Name/ name
gez./ drawn	27.04.2017	MA
gepr./ appr.	09.05.2017	BJ

Benennung/ title	Series BNC, TNC solder/crimp Serie BNC, TNC löt/crimp
------------------	--

Untert./ doc. type	Zeichnungsnr./ drawing no. R T00100A4900
--------------------------	---

Original original	A4	Blatt/ sheet von/ of 1
----------------------	----	---------------------------

Maßstab/ scale	2:1
-------------------	-----

Ersatz für / replaces	
-----------------------	--

