

Alle Rechte vorbehalten / all rights reserved © Telegärtner K.Gärtner GmbH D-71144 Steinbromm Lerchenstrasse 35 Germany Phone: +49 7157/125-0 Fax: +49 7157/125-120 www.telegaertner.com

stripping instruction
Abisoliermaße

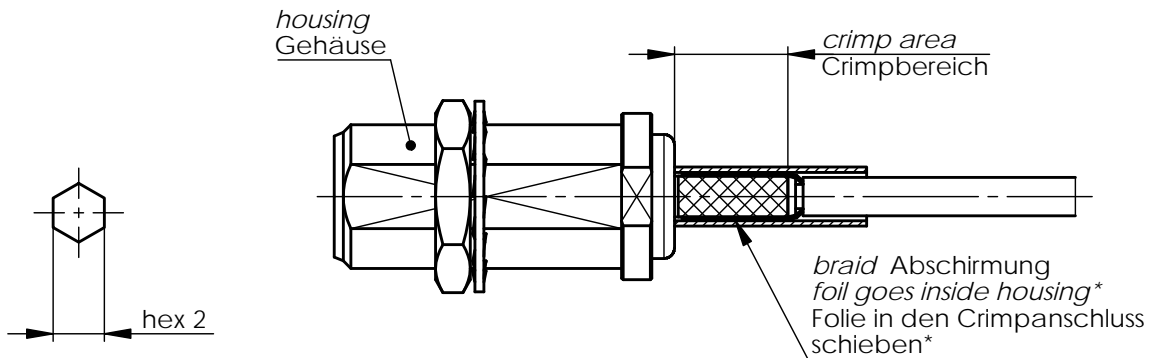
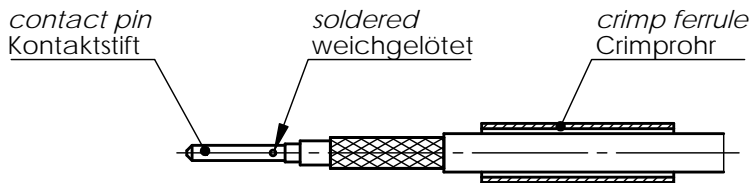
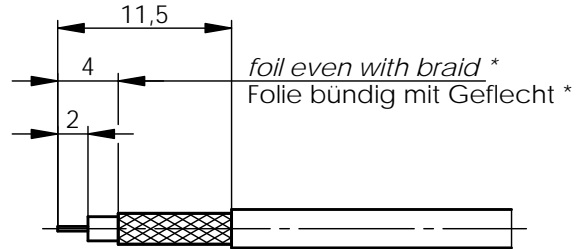

* only for cables with foil / nur für Kabel mit Folie

xx	crimp insert Crimpeinsatz	hex1 x length 6kt1 x Länge	hex2 x length 6kt2 x Länge		
36	N01003A0089		3,38x6		

And./ rev. Index	Änderungs-Nr. / revision code	Datum/ date	Name/ name

Datum/ date	Name/ name
gez./ drawn 07.08.2014	MA
gepr./ appr. 18.09.2014	KL

Benennung/ title	Series F solder/crimp Serie F löt/crimp
------------------	--

Unterl./ doc. type	Zeichnungsnr./ drawing no. R T00100A4500
--------------------------	---

Original original	A4	Blatt/ sheet von/ of 1
----------------------	----	---------------------------

Maßstab/ scale	2:1
-------------------	-----

Ersatz für / replaces	
-----------------------	--

